

**Autonics**

**ROTARY ACTUATOR TYPE  
5-PHASE STEPPER MOTOR**

**INSTRUCTION MANUAL**

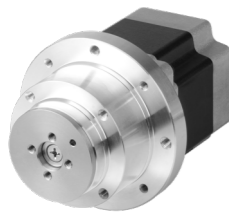

Rotary actuator type



Rotary actuator+  
built-in brake type

Thank you for choosing our Autonics product.  
Please read the following safety considerations before use.

**■ Safety Considerations**

※Please observe all safety considerations for safe and proper product operation to avoid hazards.

※⚠ symbol represents caution due to special circumstances in which hazards may occur.

**⚠ Warning** Failure to follow these instructions may result in serious injury or death.

**⚠ Caution** Failure to follow these instructions may result in personal injury or product damage.

**⚠ Warning**

- 1. Fail-safe device must be installed when using the unit with machinery that may cause serious injury or substantial economic loss. (e.g. nuclear power control, medical equipment, ships, vehicles, railways, aircraft, combustion apparatus, safety equipment, crime/disaster prevention devices, etc.)**  
Failure to follow this instruction may result in fire, personal injury, or economic loss.
- 2. Do not use the brake for safety.**  
Failure to follow this instruction may result in personal injury, or product and ambient equipment damage.
- 3. Fix the unit on the metal plate.**  
Failure to follow this instruction may result in personal injury, or product and ambient equipment damage.
- 4. Do not connect, repair, or inspect the unit while connected to a power source.**  
Failure to follow this instruction may result in fire.
- 5. Install the unit after considering counter plan against power failure.**  
Failure to follow this instruction may result in personal injury, or economic loss.
- 6. Check 'Connections' before wiring.**  
Failure to follow this instruction may result in fire.
- 7. Do not disassemble or modify the unit.**  
Failure to follow this instruction may result in electric shock or fire.
- 8. Install the motor in the housing or ground it.**  
Failure to follow this instruction may result in electronic shock, fire, or personal injury.
- 9. Make sure to install covers on motor rotating components.**  
Failure to follow this instruction may result in personal injury.
- 10. Do not touch the unit during or after operation for a while.**  
Failure to follow this instruction may result in burn due to high temperature of the surface.
- 11. Turn OFF the power directly when error occurs.**  
Failure to follow this instruction may result in electric shock, fire, or personal injury.

**⚠ Caution**

- 1. Use the unit within the rated specifications.**  
Failure to follow this instruction may result in fire or product damage.
- 2. Use dry cloth to clean the unit, and do not use water or organic solvent.**  
Failure to follow this instruction may result in fire.
- 3. Do not use the unit in the place where flammable/explosive/corrosive gas, humidity, direct sunlight, radiant heat, vibration, impact, or salinity may be present.**  
Failure to follow this instruction may result in fire or explosion.
- 4. The motor may overheat depending on the environment.**  
Install the unit at the well-ventilated environment and forced cooling with a cooling fan.  
Failure to follow this instruction may result in product damage and degradation.

※The above specifications are subject to change and some models may be discontinued without notice.  
※Be sure to follow cautions written in the instruction manual and the technical descriptions (catalog, homepage).

**■ Ordering Information**

<b>A</b>	<b>35K</b>	<b>M</b>	<b>5</b>	<b>6</b>	<b>6</b>	<b>W</b>	<b>RB</b>	<b>5</b>
Gear ratio		<b>5</b>	1:5					
		<b>7.2</b>	1:7.2					
		<b>10</b>	1:10					
Motor type		<b>R</b>	Rotary actuator type					
		<b>RB</b> <sup>※1</sup>	Rotary actuator+ built-in brake type					
Shaft type		<b>No mark</b>	Single shaft					
		<b>W</b>	Dual shaft					
Motor length		<b>6</b>	60×60mm					
Motor frame size		<b>6</b>	59.5mm					
Motor phase		<b>5</b>	5-phase					
Rated current		<b>M</b>	1.4A/Phase					
Max. holding torque		<b>35K</b>	35kgf·cm					
		<b>40K</b>	40kgf·cm					
		<b>50K</b>	50kgf·cm					
		<b>A</b>	Autonics motor					

※1: Built-in brake type provides single shaft type only.

**■ Specifications**

Frame size 60mm			
Model	A35K-M566(W)-R5	A40K-M566(W)-R7.2	A50K-M566(W)-R10
	A35K-M566-RB5	A40K-M566-RB7.2	A50K-M566-RB10
Max. holding torque <sup>※1</sup>	35 kgf·cm (3.4 N·m)	40 kgf·cm (3.9 N·m)	50 kgf·cm (4.9 N·m)
Rotor moment of inertia <sup>※2</sup>	280 g·cm <sup>2</sup> (280×10 <sup>-7</sup> kg·m <sup>2</sup> )		
Rated current	1.4 A/Phase		
Basic step angle	0.144° / 0.072° (Full/Half step)	0.1° / 0.05° (Full/Half step)	0.072° / 0.036° (Full/Half step)
Gear ratio	1:5	1:7.2	1:10
Allowable speed range	0 to 360rpm	0 to 250rpm	0 to 180rpm
Backlash [min]	±20' (0.33 )		
Electro-Magnetic Brake	Rated excitation voltage	24VDC±10%	
	Rated excitation current	0.33A	
	Static friction torque	8kgf·cm	
	Rotation part inertia	29×10 <sup>-7</sup> kg·cm <sup>2</sup>	
	Insulation class	B type (130°C)	
B type brake	Power on: brake is released, power off: brake is operating		
	Operating time	Max. 20ms	
Releasing time	Max. 25ms		
Absolute position error	±20' (0.33 )		
Lost motion	±25' (0.33 )		
Weight <sup>※3</sup>	• Rotary actuator type: approx. 1.4kg (approx. 1.3kg)		
	• Rotary actuator+built-in brake type: approx. 1.7kg (approx. 1.6kg)		

※1: Max. holding torque is maintenance torque in stopping the motor when supply the rated current and is standard method for comparing the performance of motors.  
※2: Moment of rotor inertia indicates a part, except Gear Head part.  
※3: The weight includes packaging. The weight in parenthesis is for unit only.

**◎ Common specifications**

Insulation class	B type (130°C)
Insulation resistance	Over 100MΩ (at 500VDC megger) between motor coil-case
Dielectric strength	1 kVAC 50/60Hz for 1 min between motor coil-case
Environment	Ambient temp. -10 to 50°C, storage: -25 to 85°C
	Ambient humi. 35 to 85%RH, storage: 35 to 85%RH
Protection structure	IP30 (IEC34-5 standard)

※Environment resistance is rated at no freezing or condensation.

**■ Connection Diagram**

Autonics 5-phase stepper motors use pentagon wiring methods. Therefore, it is a proper product for the 5-phase stepper motor driver which is working as a bipolar pentagon driving method. The connections of each phase and each color of the lead-wire are as follows:

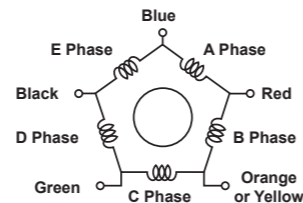

**■ Dimensions**

◎ AK-M566(W)-R◎

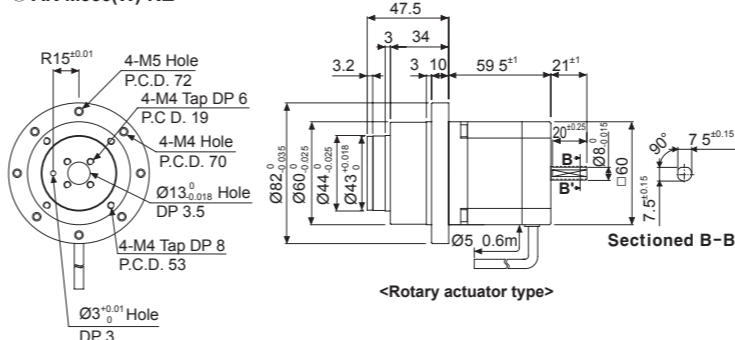

※These dimensions are for dual shaft models. Single shaft models do not include shafts indicated in the dotted lines.

◎ AK-M566-RB◎

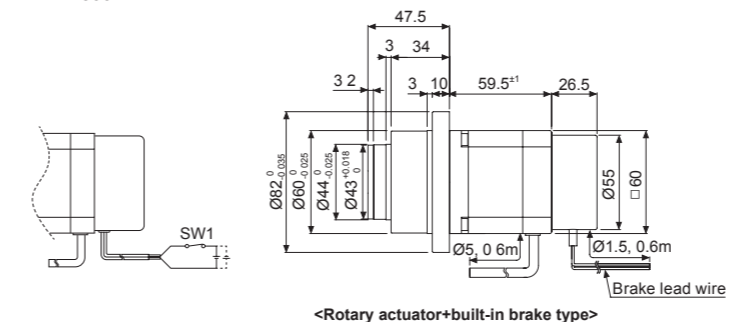

※Built-in brake type provides single shaft type only.

**■ Installation**

**1. Motor installation method**

- Install the rotary actuator against the metal panel which has high thermal conductivity such as iron or aluminum because of vibration and heat radiation of the motor. Mounting plates is required to have over 8mm of thickness.
- As shown in the figure below, total 4 mounting TAP holes on F1 and F2 are used to fix rotary actuator. In case of using M4, screw tightening torque needs to be 2N·m, and in case of M5, 4.4N·m.

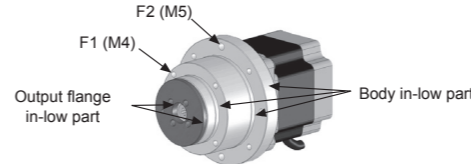

- Do not apply excessive force on motor cable when installing rotary actuators. Do not forcibly pull or insert the cable. Do not move the motor cable repeatedly with excessive force, or it may cause poor connection or disconnection of the cable. In case of frequent cable movement or excessive force is required, proper safety countermeasures must be ensured.

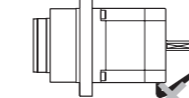

**2. Installation condition**

- Install the motor in a place that meets certain conditions specified below. It may cause product damage if instructions are not following.
- The inner housing installed indoor (This unit is manufactured and designed for attaching to equipment. Install a ventilation device.)
  - Within -10 to 50°C (at non-freezing status) of ambient temperature
  - Within 35 to 85%RH (at non-dew status) of ambient humidity
  - The place without explosive, flammable and corrosive gas
  - The place without direct ray of light
  - The place where dust or metal scrap does not enter into the unit
  - The place without contact with water, oil, or other liquid
  - The place without contact with strong alkali or acid material
  - The place where easy heat dissipation could be made
  - The place where no continuous vibration or severe shock
  - The place with less salt content
  - The place with less electronic noise occurs by welding machine, motor, etc.
  - The place where radioactive substances and magnetic fields does not exist and is not in the vacuum status

**3. Installation of accessories (index table, arm, etc.)**

- Mount the accessory (index table or arm) on output axis flange using M4 screw. Note that Ø13 in-low part is processed with C0.3. It is necessary to process the accessory under C0.2 to mount. Place a positioning pin on flange's positioning hole and push it in. Make sure not to place the pin on output flange.
- Do not use a hammer to mount the accessory (table or arm). It may cause product damage. Mount the accessory with hands in a gentle manner.
- Make sure that accessory mounted on output axis to be fixed as tight as possible. It may cause an accident if an actuator is detached from the motor while driving.

**4. Motor operation**

- Observe the rated product specification.
- Do not apply rotational load on the motor while it stops.
  - Do not apply excessive load on the motor while driving. It may cause motors to miss a step.
  - Use a sensor for home searching or division completed position detecting.

**5. Application**

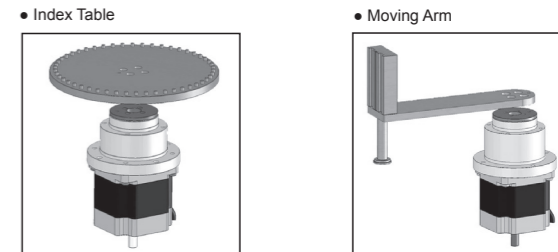

**6. Sensor attachment**

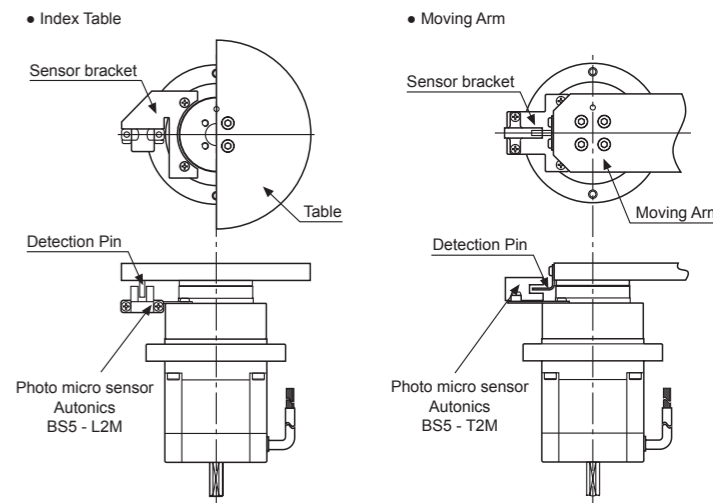

**■ Cautions during Use**

- Follow instructions in 'Cautions during Use'. Otherwise, it may cause unexpected accidents.
- Using motors at low temperature may cause reducing ball bearing's grease consistency and friction torque is increased. Start the motor in a steady manner since motor's torque is not to be influenced.
- When power is supplied or not to the brake, the unit may occur clack sound.
- When drive the motor, supply power to electro-magnetic brake for releasing the brake. When the brake pad is worn out, the product life cycle is shorten, the rated static friction torque is reduced.
- For using motor, it is recommended to maintenance and inspection regularly.
  - Unwinding bolts and connection parts for the unit installation and load connection
  - Strange sound from ball bearing of the unit
  - Damage and stress of lead cable of the unit
  - Connection error with driver
  - Inconsistency between the axis of motor output and the center, concentric (eccentric, declination) of the load, etc.
- This unit may be used in the following environments.
  - Indoors (in the environment condition rated in 'Specifications')
  - Altitude max. 2,000m
  - Pollution degree 2
  - Installation category II

**■ Major Products**

- Photoelectric Sensors
- Fiber Optic Sensors
- Door Sensors
- Door Side Sensors
- Area Sensors
- Proximity Sensors
- Pressure Sensors
- Rotary Encoders
- Connector/Sockets
- Switching Mode Power Supplies
- Control Switches/Lamps/Buzzers
- I/O Terminal Blocks & Cables
- Stepper Motors/Drivers/Motion Controllers
- Graphic/Logic Panels
- Field Network Devices
- Laser Marking System (Fiber, CO<sub>2</sub>, Nd: YAG)
- Laser Welding/Cutting System
- Temperature Controllers
- Temperature/Humidity Transducers
- SSRs/Power Controllers
- Counters
- Timers
- Panel Meters
- Tachometer/Pulse (Rate) Meters
- Display Units
- Sensor Controllers